

Multi Channel Transmitter

Active Splitter (RF20)

Installation Instructions



Multi Channel Transmitter (MCTX) - Installation of an Active Splitter

Introduction

Two or more upconverters are often required in installations which require them to be located some distance apart, such as separate gyms at different ends of a building. The Active splitter and amplifier (RF20) is designed to meet the requirement where the cable loss exceeds the 10dB allowed between the processor and upconverter. The unit has two outputs to feed two upconverters or it can be used as a line amplifier using only one output.

Signal levels

Care will be required in the design of the system to avoid overload and high intermod of the VHF amplifiers. The output signal from the Active Splitter should not exceed -30dBm. A spectrum analyser will be required to set the optimum signal levels.

Power Supply

The Active Splitter requires a +15v DC power supply which is obtained from the DC power output of the MCTX processor. Power can be fed on to subsequent splitters and the upconverters from the BNC connectors on the active splitter which are connected in parallel.

PCB Layout

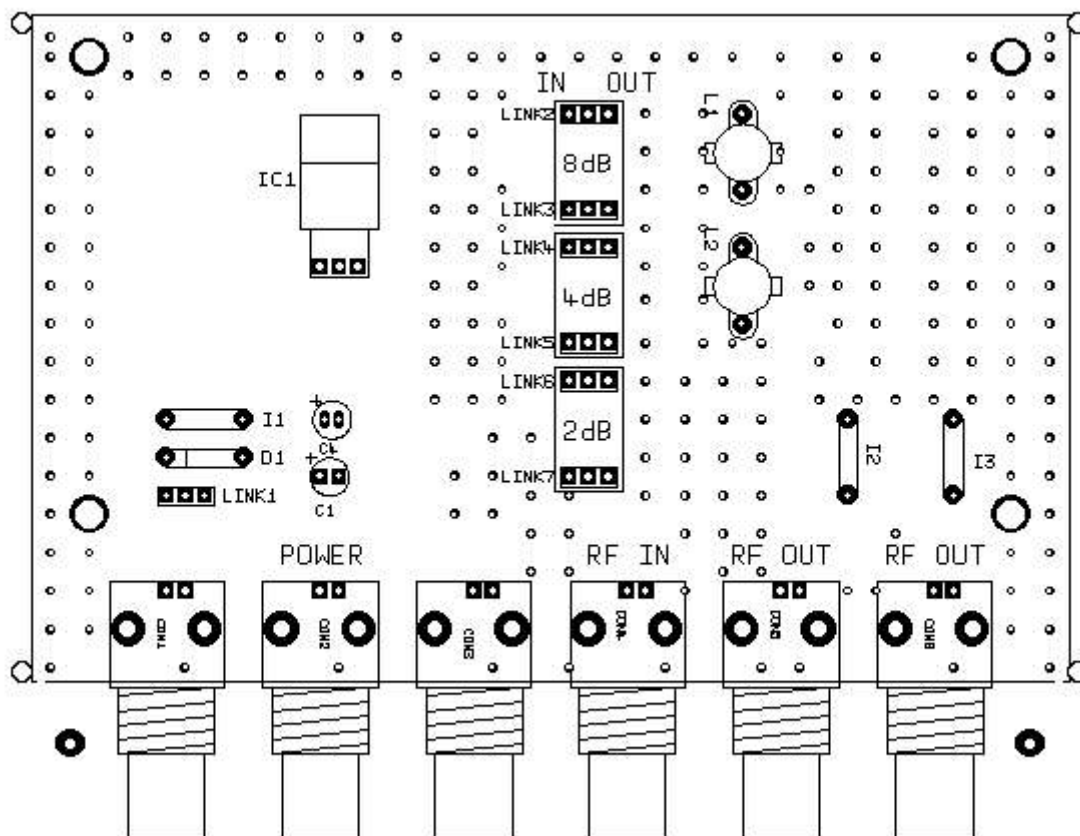



Compliance

All systems are tested at the factory before shipping to ensure that they comply with the following EU directives and standards:

Council Directive 89/336/EEC the EMC directive

- European Standards
- 1) EN 50 081-1 Emission
 - 2) EN 50 082-2 Immunity
 - 3) EN 60 555 Conducted Emissions

- Conformity Criteria
- 1) Radiated emissions are less than 30 dB μ V/m @ 10m from the equipment.
Conducted emissions are less than 56dB μ V/m.
 - 2) The performance of the equipment will not be impaired by a radiated signal in the band 27MHz to 500MHz with a signal strength 3V/m and with 80% modulation
 - 3) The AC power input current harmonics are within the limits set by EN 60 555-3,-3. The conducted RF emissions are below the limits described in EN55 022 class B.

Council Directive 73/23/EEC The Low Voltage Directive as amended by Article 13 of Council Directive 93/68/EEC

Council Directive 1999/5/EEC the R&TTE Directive

European Standard EN 60065
UK Interface requirements IR2030
ETSI standard EN 301 357

Council Directive 2002/95/EC the RoHS Directive

The performance of the transmitter must be checked when the system has been installed to ensure that it still fully complies.

Instructions for testing are included later in this document.

MCTX Standard Installation

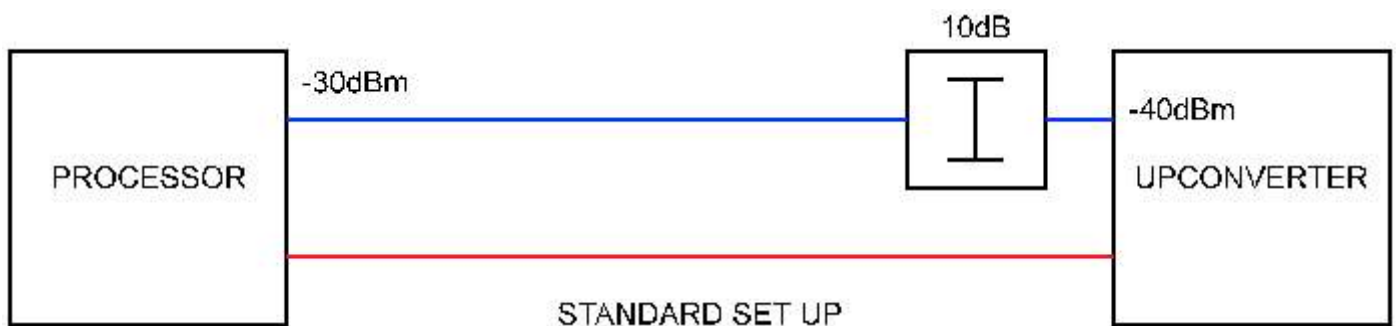

The processor is connected to the upconverter with an attenuator to provide the correct input signal of -30dBm. For the best performance the attenuator should be placed next to the input of the upconverter.

Standard Installation with a long cable run

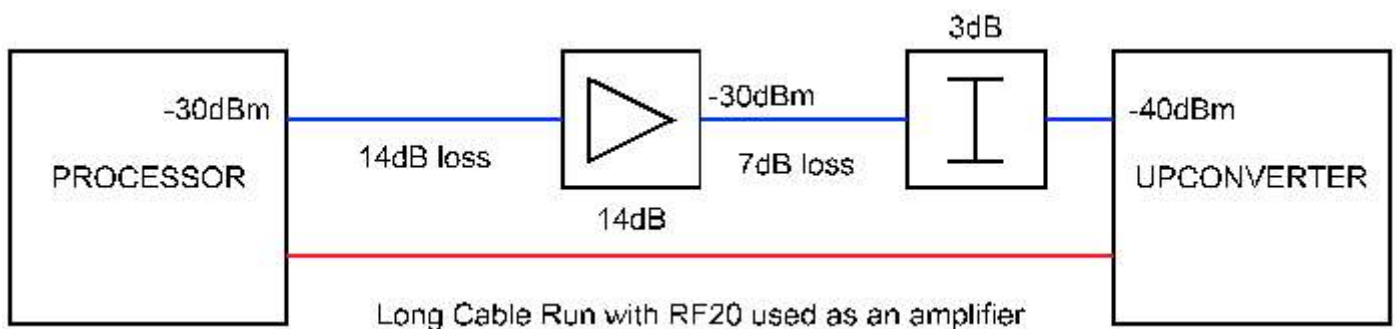

When the cable loss exceeds 10dB between the processor and upconverter (shown in the standard installation) the active splitter can be used as an amplifier. The amplifier (RF20) has a maximum gain of 14dB so a cable loss of 14dB between the output of the processor and the input of the amplifier can be accommodated. For losses of less than 14dB the amplifier gain can be adjusted using the internal attenuators so the amplifier gain is equal to the cable loss. Upto 10dB of cable loss after the amplifier can also be allowed but if the cable loss is less than 10dB then an attenuator will be required to reduce the input to the upconverter to -40dBm. The location of the amplifier and the attenuator is important so that the RF signals are not degraded.

MCTX with two upconverters using a passive splitter

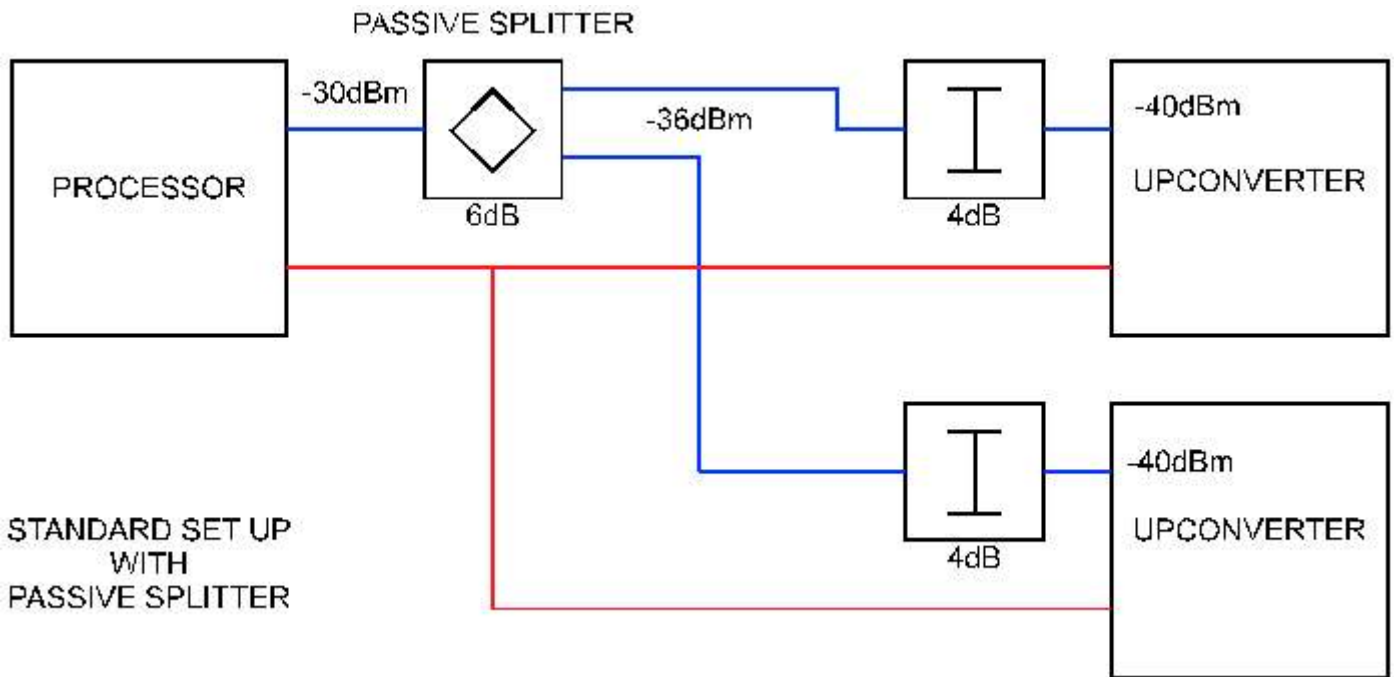

This is the basic arrangement which is used when the cable loss does not exceed 4dB. The passive splitter has a loss of 6dB so the maximum cable run with URM43 is 30 metres. For longer cable runs an amplifier (RF20) will be required.

MCTX with two upconverters using an active splitter

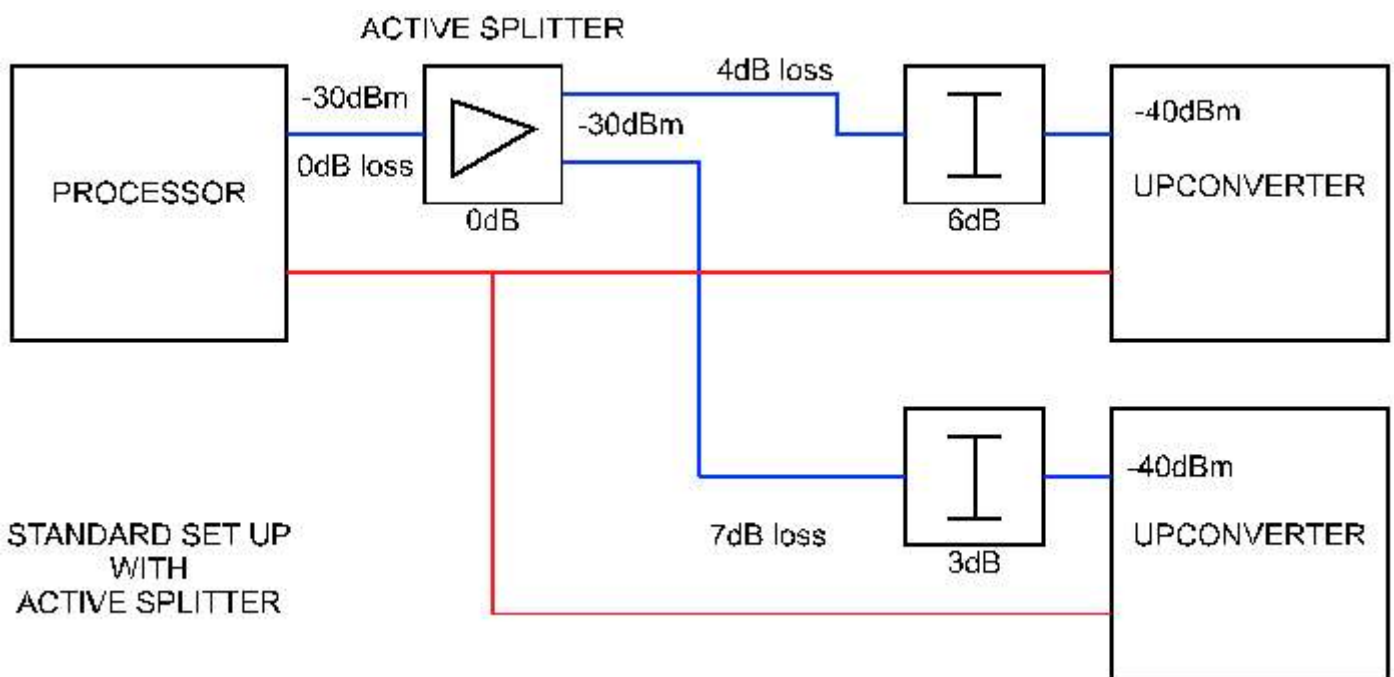

When the cable loss is greater than that allowed by the passive splitter then an active splitter must be used. If the cable loss between the processor and the upconverter is less than 10dB then the splitter can be located adjacent to the processor. Set the active splitter input attenuator to the maximum value of 14 dB so the output does not exceed -30 dBm. For cables where the loss is less than 10dB then an attenuator should be used to build out the loss so the input to the upconverter is at or below -40 dBm. The two cables to the upconverters do not need to be the same length. When the cable loss is greater than 10dB the splitter can be located away from the processor. The internal attenuator is set so that the output is at -30dBm. If the cable loss is 8dB then the internal attenuator should be set to 4dB. For very long cable runs then extra active splitters can be used to amplify the signal.

MCTX with long cable runs to the upconverter

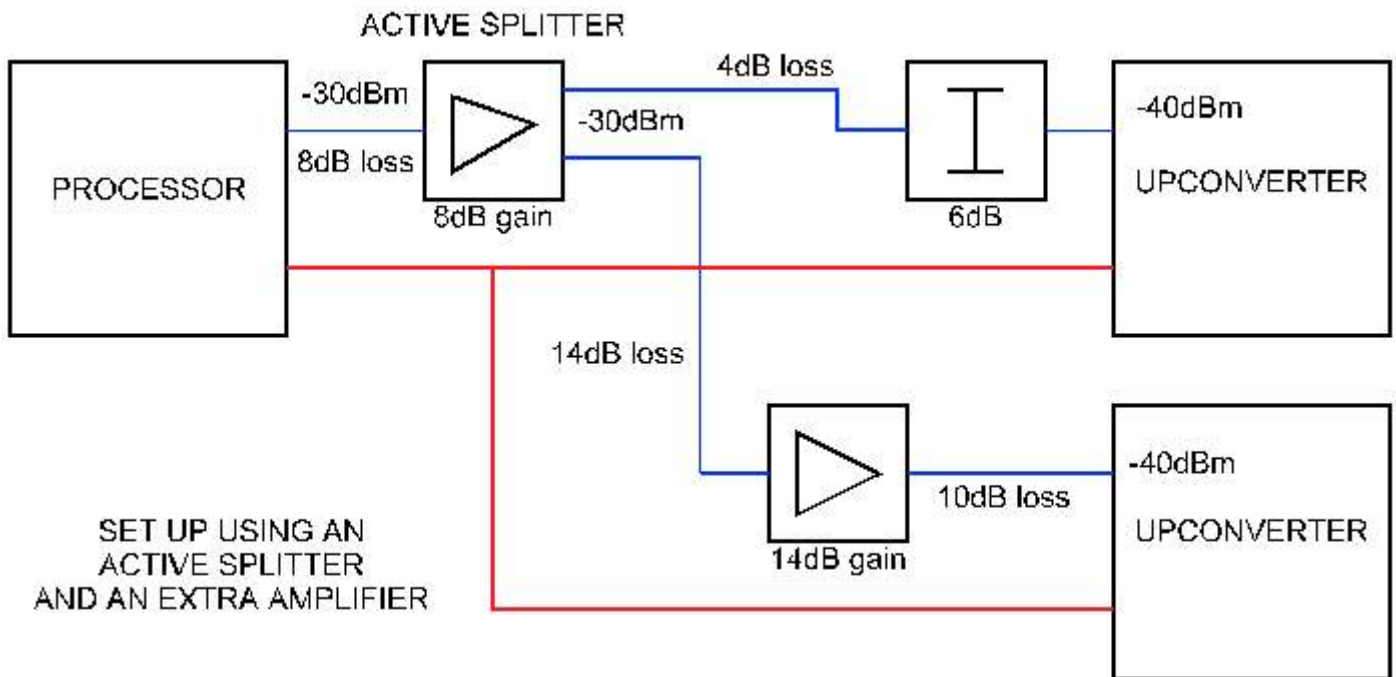

This arrangement will allow systems to be installed with long cable runs. Care should be taken to ensure that the signals do not overload the splitter amplifiers which would cause high levels of intermod and distortion whereas too low a signal will reduce the signal to noise ratio. A spectrum analyser will be required to optimise the system.

Appendix I

Coax Cable Losses

Cable	Impedance	Loss per Metre	
		@ 100 MHz	@ 1000 MHz
RG 58	50 ohms	0.21 dB	0.76 dB
RG 223	50 ohms	0.14 dB	0.29 dB
UR M43	50 ohms	0.13 dB	0.46 dB
UR M67	50 ohms	0.07 dB	0.25 dB
UR M70	75 ohms	0.15 dB	0.52 dB
UR M76	50 ohms	0.16 dB	0.53 dB
CT100	75 ohms	0.06 dB	0.20 dB

Appendix ii

Radio Frequencies

VHF frequencies used between the MCTX processor and the upconverter

Channel 1	96.90 MHz
Channel 2	96.65 MHz
Channel 3	96.40 MHz
Channel 4	96.15 MHz
Channel 5	95.90 MHz
Channel 6	95.65 MHz
Channel 7	95.40 MHz
Channel 8	95.15 MHz
Channel 9	105.40 MHz
Channel 10	104.10 MHz
Channel 11	103.10 MHz
Channel 12	102.4 MHz
Channel 13	101.30 MHz
Channel 14	100.70 MHz
Channel 15	99.80 MHz
Channel 16	99.00 MHz



Specification

Gain	14dB
Attenuators	2dB, 4dB and 8dB
Frequency response	± 1 dB from 95MHz to 105MHz
Low pass filter type	5 pole Butterworth (30 dB per octave)
Low pass cutoff frequency	120 MHz
Maximum output	-30dBm
Impedance	50 ohms
Power requirements	+7 to +15v DC at 10mA
Connectors	6 x BNC (3 for power, 1 for VHF input and 2 for VHF outputs)
Size	190mm x 150mm x 50mm



Audeon products are manufactured in the UK by

M-Jay Electronics Limited

Albion Mills, Church Street, Morley, Leeds. LS27 8LY

Phone +44 113 252 4956

Fax +44 113 252 5542

Service +44 113 252 5582

e-mail to: service@audeon.co.uk

www.audeon.co.uk

www.m-jay.co.uk/audeon